

Front Suspension

Ride Height: _____
 Camber: _____
 Toe: _____
 Anti-Roll Bar: _____
 Arm Type: _____
 Tower Type: _____
 Wheel Hex: _____
 Steering Block KPI: _____
 Caster Block Insert: 0 +2.5 +5
 Bulkhead Type: _____
 Kick-Up Angle: -2.5 0 +2.5
 Steering Stop Spacing: _____
 Caster Block Spacing: Fwd Back
 Notes: _____

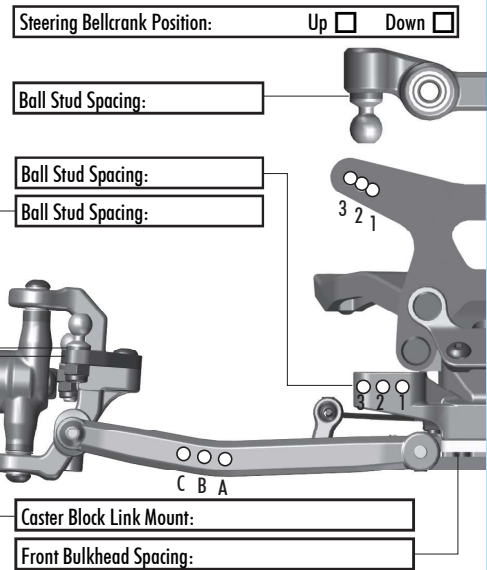
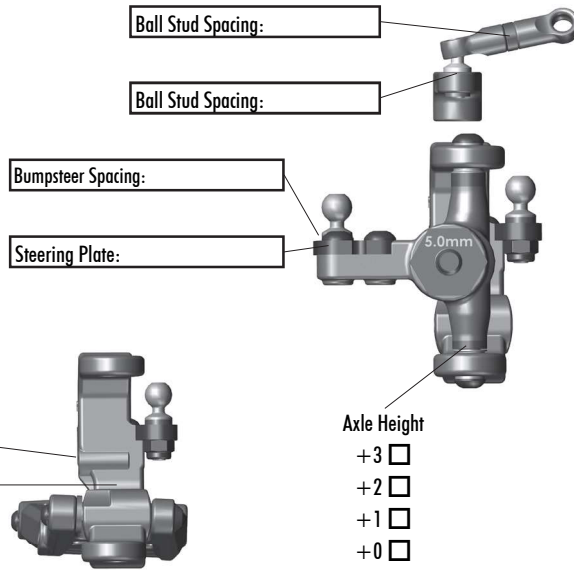

Rear Suspension

Ride Height: _____
 Camber: _____
 Anti-Roll Bar: _____
 Arm Type: _____
 Tower Type: _____
 Arm Spacing: Fwd Mid Back
 Wheel Hex: _____
 Hub Type: Std HRC
 Hub Spacing: Fwd Mid Back
 Drive Shaft: CVA's Universal
 Notes: _____

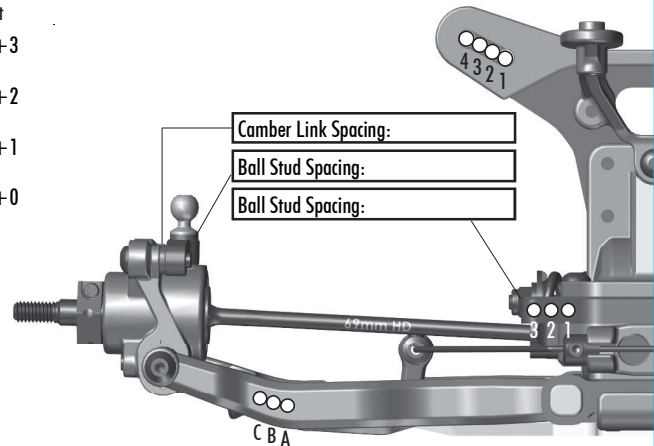
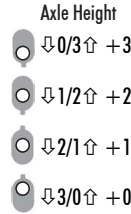
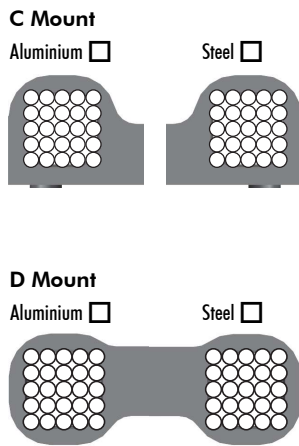

Electronics

Radio: _____ Servo: _____
 EPA (%) - Throttle: _____ Brake: _____
 ESC: _____
 ESC Settings: _____
 Motor / Wind: _____ Timing: _____
 Pinion: _____ Spur: _____
 Battery Mount: Std Offset
 Back 1 2 3 4 5 Fwd
 Battery: _____ Weight: _____
 Notes: _____

Drivetrain

Differential Ball Steel
 Height: _____
 Setting: _____
 Notes: _____

Slipper Clutch

Type: _____
 # of Pads: _____
 Setting: _____
 Notes: _____

Shocks

	Front		Rear	
Piston:				
Thickness:				
Fluid:				
Spring:				
Limiters:	In: _____	Out: _____	In: _____	Out: _____
Stroke:				
Eyelet:				
Cup Offset:	0 <input type="checkbox"/> +5 <input type="checkbox"/> +9 <input type="checkbox"/>		0 <input type="checkbox"/> +5 <input type="checkbox"/> +9 <input type="checkbox"/>	
Kashima Bodies <input type="checkbox"/> Chrome Shafts <input type="checkbox"/> Machined Spacers <input type="checkbox"/>				
Notes: _____				



Track Information

Size: _____
 Composition: _____
 Traction: _____
 Moisture: _____
 Surface: Bumpy Smooth _____
 Temperature: _____
 Notes: _____

Tires

Front Tires: _____
 Front Compound: _____
 Front Insert: _____
 Rear Tires: _____
 Rear Compound: _____
 Rear Insert: _____
 Wheel (F/R): _____
 Notes: _____

Body, Weight

Body: _____
 Front Wing: _____
 Rear Wing: _____
 Wing Angle: 0° 3° 6°
 Chassis Length: _____
 Servo Weights: _____
 Electronics Weights: _____
 Total Vehicle Weight: _____

Vehicle Comments

Notes: _____